

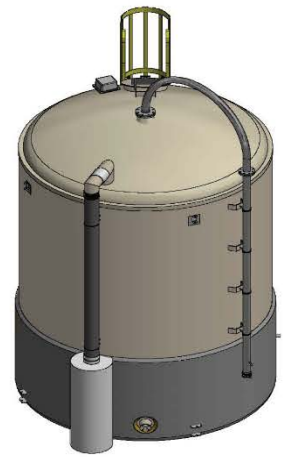

VIEW 1



VIEW 2



VIEW 3

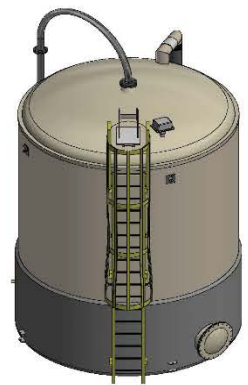

VIEW 4



BRINE-TEK™

Operation & Maintenance

Instruction Manual

01-29-2026

 (616) 794-1130

 sales@beldingtank.com

 www.beldingtank.com

 (616) 794-3666



200 N. Gooding Street – P.O. Box 160 – Belding, MI 48809-0160

 Toll Free: (800) 253-4252



OPERATION & MAINTENANCE INSTRUCTIONS

Belding Tank Technologies (BTT)

TABLE OF CONTENTS

| | |
|--|----------|
| GENERAL | Page 2 |
| TANKS FOR FOOD APPLICATION | Page 2 |
| AFTER THE TANK IS PUT INTO SERVICE | Page 3 |
| TANK USAGE | Page 3 |
| SALT LOADING | Page 4 |
| DUST CONTROL | Page 4 |
| BRINE HANDLING | Page 4 |
| WATER MAKE-UP | Page 4 |
| MAINTENANCE AND CLEANING | Page 4-5 |
| SIDE MANWAY BOLTING (20" thru 36" Current) | Page 6 |
| SIDE MANWAY BOLTING (20" & 24") | Page 7 |
| SIDE MANWAY BOLTING (30" & 36") | Page 8 |
| FLANGE BOLTING (1" – 14") | Page 9 |
| FLANGE BOLTING (16" – 24") | Page 10 |
| TORQUE INCREMENTS (LEGACY CROSS-PATTERN) | Page 11 |
| FLANGE ALLOWABLE LOADS | Page 12 |





OPERATION & MAINTENANCE INSTRUCTIONS

GENERAL

Because of FIBERGLASS REINFORCED PLASTIC tanks unique, physical and structural characteristics; they are flexible, lightweight, corrosion resistant, and stronger than tanks made of other plastic materials.

Care, however, should be taken to follow the Handling and Installation instructions.

If your fiberglass tank has been installed with insulation and a Heat Maintenance Unit, the wiring instructions are placed inside the control box.

If you have a BTT Dual-Tek™ double wall tank and your tank was supplied with BTT's Leak Detection System and/or Desiccant Filter, please refer to the instructions supplied with those items.

Once the tank has been properly installed and placed in service, BTT recommends regular routine inspections as a part of your preventative maintenance program.

The care and operation of FRP vessels rely mostly on common sense. To maximize trouble free service, Belding Tank recommends the following:

1. Inspect your vessel thoroughly upon receipt.
2. Follow the Handling and Installation instruction.
3. Wash your vessel thoroughly w/detergent and rinse before putting in service (see FDA Requirements)

TANKS FOR FOOD APPLICATION

BTT tanks that utilize AOC Isophthalic, Derakane Signia 411, Derakane Signia 411-WSR or Derakane Signia 441 resins will comply with U.S. Food, Drug and Cosmetic Act, as amended, and applicable FDA regulations (21 cfr 177.2420). These tanks may be used as components intended for repeated use in contact with food, subject to certain limitations described in that regulation.

BTT tanks are chemically acceptable in processing or storage areas for contact with meat or poultry food products prepared under federal inspection and used at temperatures below 180° F. This acceptance has been given by the United States Department of Agriculture.

Prior to shipping your tank, BTT applies a (4) hour heat cure followed by a water rinse to the tank interior.





OPERATION & MAINTENANCE INSTRUCTIONS

TANKS FOR FOOD APPLICATION (Cont'd.)

After installation and before your tank is put into service, attention to the following procedures is important to achieve FDA compliance:

1. After tank installation, steam-treat or steep tank with hot water for 8-16 hours at 160° – 180° F. This should remove all residual styrene from the laminate surface.
2. Wash the tank thoroughly with detergent and rinse it thoroughly.
3. Check state and local regulations for required compliance in addition to the above recommendations.

AFTER THE TANK IS PUT IN SERVICE:

1. Keep the vessel clean.
 - a. It will remain more aesthetically pleasing.
 - b. If the tank is ever damaged, it will be evident.
2. Make a visual tank inspection inside and outside the tank every 6-12 months.
3. Keep the Vent dust bag clean (see DUST CONTROL on page 4).
4. Rapid temperature changes to the fiberglass tank **MUST BE AVOIDED**, especially going from a hot tank to a cold tank.

TANK USAGE

This tank has been sold for a specific chemical storage application. Before changing the chemical environment, consult with BTT (your warranty may be void without written authorization from BTT)

1. Do not allow the stored material to freeze.
2. BELDING TANK standard tanks are NOT designed for pressure or vacuum other than liquid head. Do not restrict the tank vent. Vapor removal equipment (if installed) must not cause any pressure or vacuum conditions.
3. The rated capacity of the tank is to the top of the straight side only.

If any of the above guidelines are not followed or if any modifications are made without written approval from BTT, it could result in structural damage to the tank and would void the existing warranty.





OPERATION & MAINTENANCE INSTRUCTIONS

SALT LOADING

1. The salt truck should connect the 4" delivery hose to the fitting on the salt fill pipe.
2. After airflow is established, water should be added through the 3/4" nipple on the salt fill pipe at a rate of approximately 4 to 5 gallons per minute.
3. The water injection will dissolve the majority of the dust formed during the loading operation.
4. When the truck has been emptied, the water injection should be shut off before stopping the flow of air in the fill pipe.

DUST CONTROL

A polyester dust bag and clamp are provided for installation on the 8" vent pipe. This is generally not required if water injection is used, but it may be utilized as an additional protection device to avoid salt dust. If water injection cannot be used, it is very important to install the dust bag for each unloading.

IMPORTANT – THE DUST BAG MUST BE REMOVED AFTER EACH SALT DELIVERY AND RINSED THOROUGHLY IN FRESH WATER TO REMOVE THE ACCUMULATED SALT DUST. AFTER DRYING, THE BAG SHOULD BE STORED IN READINESS FOR THE NEXT SALT DELIVERY.

BRINE HANDLING

The brine maker can be operated by gravity flow or pump, but the flow rate should not exceed 20 GPM (8 foot diameter), 25 GPM (9 foot diameter), 33 GPM (10 foot diameter), 45 GPM (11.5 foot diameter), 50 GPM (12 foot diameter) or 66 GPM (14 foot diameter) when using granulated salt grades. Maximum flows for Rock Salt should be approximately 60% of these values.

WATER MAKE-UP

If high grade salt is being used and brine purity is an important factor, the make-up water should be softened. If not, the make-up should be clean plant water.

MAINTENANCE AND CLEANING

Granulated Salts

This grade of salt is totally soluble; therefore, a complete clean-out is required infrequently. However, in all "Down Flow" brine making systems, there is a tendency for "fines" to collect in the lower section of the salt bed-dissolving zone. This collection of fines tends to produce a pressure drop across the salt bed, until finally the weakest point will break through and channel. Undissolved salt and fine gravel are usually found in the salt brine due to this sudden increase in velocity.





OPERATION & MAINTENANCE INSTRUCTIONS

MAINTENANCE AND CLEANING (Cont'd)

To avoid this condition, every three to six months (depending on the salt used and brine flow rates) water should be introduced through the brine outlet fitting to dissolve the fines.

The brinemaker should first be taken out of service. A supply of fresh water needs to be temporarily connected to the brine outlet piping. Approximately 1,000 gallons of fresh water at a flow of 8 to 10 GPM should be added, once completed return to the normal piping arrangement. If the brinemaker is immediately returned to service, the first brine will be less than saturated, and a sufficient quantity should be drawn off until the brine becomes saturated before returning the system to normal plant operation.

A major clean out may be required after a number of years of service. A bulk salt dissolving system tends to accumulate the impurities and foreign matter delivered with the salt. This might be small amounts of dirt from the truck as well as rubber particles from worn or damaged delivery hose. Many of the particles are static in nature and tend to stick to the upper areas of the tank.

In most cases the tank can be cleaned as follows:

Consume the salt to as low a level as practical, still maintaining saturated brine. This will be at about the one-foot level, depending somewhat on the flow rate.

Continue to dissolve away the remaining salt until the side manhole can be opened. Then connect a supply of fresh water to the brine outlet and introduce water through the brine collector system and the gravel bed, allowing it to overflow out of the side manhole. If necessary, the walls should be washed down with water or scrubbed with a long-handled brush.

The backwash and overflow should be continued to keep the dirt from dropping into the gravel bed. In very extreme conditions, it may be necessary to replace the gravel support bed.

Rock Salts

When rock salt is being used there will be a residue of un-dissolved calcium sulphate remaining in the bottom of the brinemaker. This will be mixed with about 50% fine salt. As the impurities accumulate, the pressure drop increases across the dissolving zone until a break through zone occurs, which will carry solids out with the brine, due to the sudden localized increase in velocity.

A rock salt dissolver should be taken out of service and cleaned before reaching the point of channeling. The tonnage of salt that can be dissolved before reaching this point is partly determined by the flow rate, but in general depending on the Rock Salt quality, tanks should be cleaned every 8 to 12 loads.

The Rock Salt Brinemaker should be cleaned by using as much salt inventory as practical. The liquid should then be drained, and the side manhole opened. The mixture of impurities and salt should be shoveled out and carried away for disposal. Care should be taken to avoid breaking the brine collection pipes, plenum and outlet piping. The collection pipes and plenum should be thoroughly washed out and repositioned, if necessary. All internal piping and supports should be carefully inspected for any breaks or damage before placing the brinemaking system back into service.



OPERATION & MAINTENANCE INSTRUCTIONS

SIDE MANWAY BOLTING SEQUENCE

(BUILT 12-11-17 TO PRESENT)

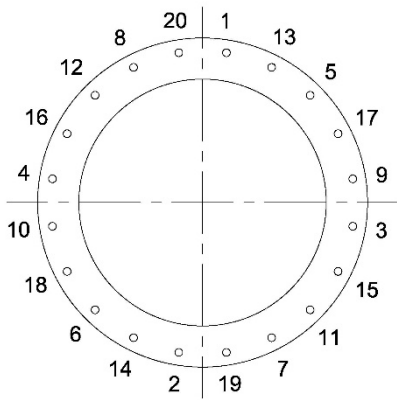

20" & 24" Side Manway

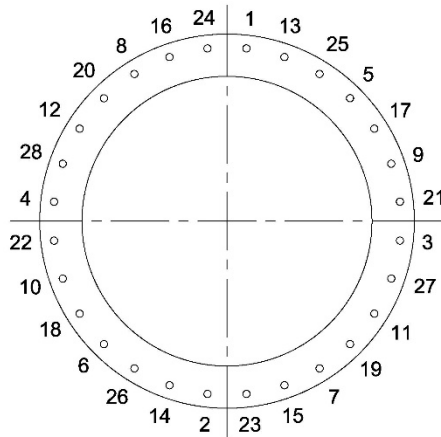

30" Side Manway

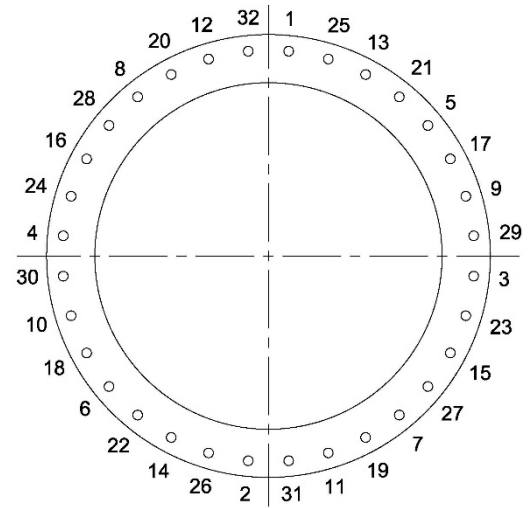

36" Side Manway

Drawings not to scale

Side Manway Bolt Torque is 95 ft. lbs. (lubricated)

Torque tolerance is ± 10 for all sizes.

OPERATION & MAINTENANCE INSTRUCTIONS

SIDE MANWAY BOLTING SEQUENCE

(BUILT PRIOR TO 12-11-17)

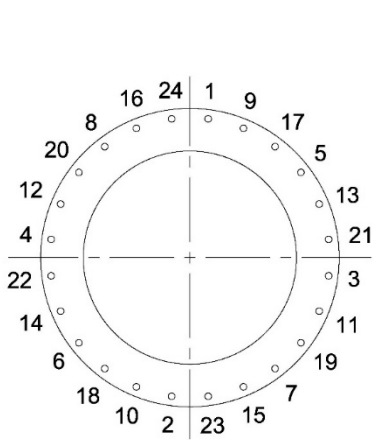

20" Side Manway

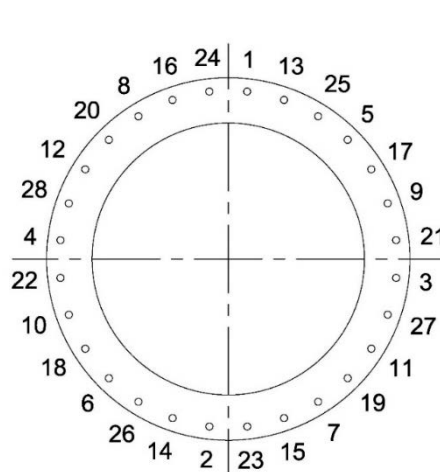

24" & 30" Side Manway

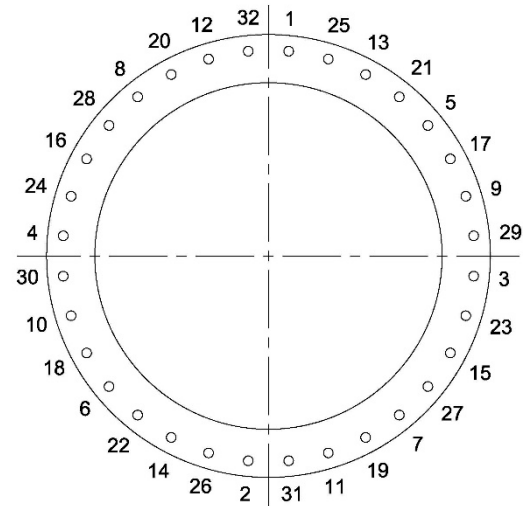

36" Side Manway

Drawings not to scale

Side Manway Bolt Suggested Torque is 50 ft. lbs. (lubricated)

Torque tolerance is ± 10 for all sizes.

OPERATION & MAINTENANCE INSTRUCTIONS

FLANGED NOZZLE BOLTING SEQUENCE

CAUTION: A flange spacer **MUST BE USED** when bolting FRP flanges to raised face flanges. Use only full-face gaskets. Do NOT over torque flange bolts.

When bolting to PVC/CPVC, note the allowable bolt torque of the mating flange.

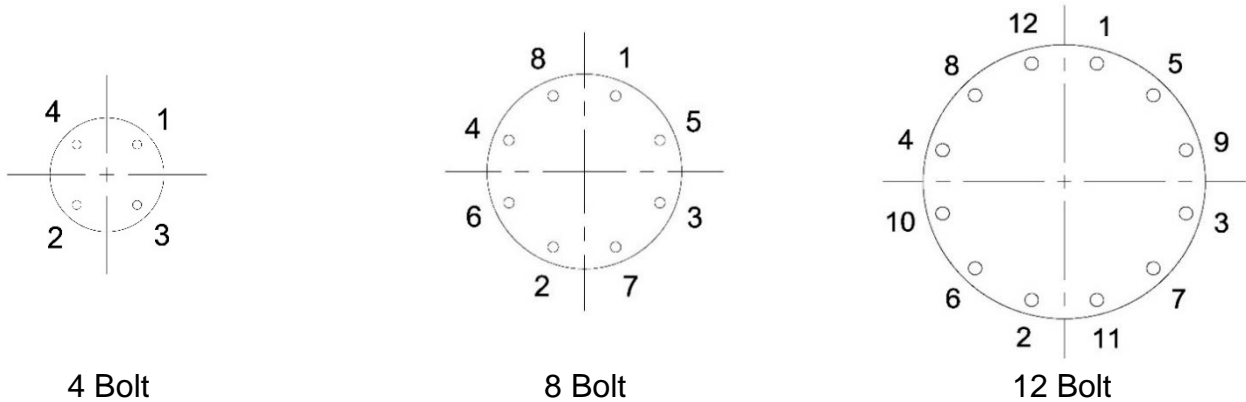

Drawings not to scale

Flanged Nozzle PSI Rating & Suggested Torque (lubricated).

| Diameter | PSI Rating | Suggested Torque |
|----------|------------|------------------|
| 1" | 150 | 50 ft. lbs. |
| 1-1/2" | 150 | 50 ft. lbs. |
| 2" | 150 | 95 ft. lbs. |
| 2-1/2" | 150 | 95 ft. lbs. |
| 3" | 150 | 95 ft. lbs. |
| 4" | 150 | 95 ft. lbs. |
| 6" | 100 | 115 ft. lbs. |
| 8" | 50 | 115 ft. lbs. |
| 10" | 50 | 185 ft. lbs. |
| 12" | 50 | 185 ft. lbs. |
| 14" | 50 | 275 ft. lbs. |

Torque tolerance is ± 5 for sizes 12" and smaller and ± 10 for sizes greater than 12".

OPERATION & MAINTENANCE INSTRUCTIONS

FLANGED NOZZLE BOLTING SEQUENCE

CAUTION: A flange spacer **MUST BE USED** when bolting FRP flanges to raised face flanges. Use only full-face gaskets. Do NOT over torque flange bolts.

When bolting to PVC/CPVC, note the allowable bolt torque of the mating flange.

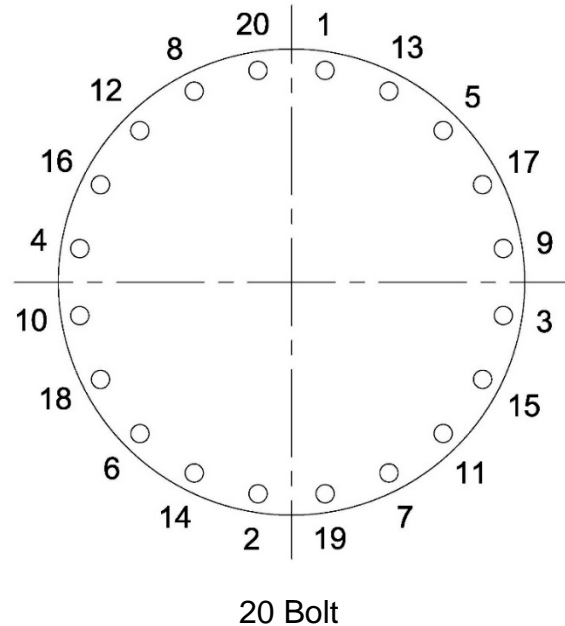
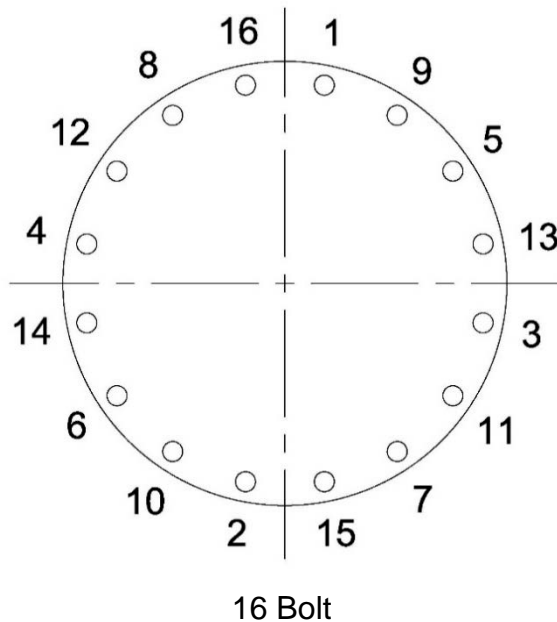

Drawings not to scale

Flanged Nozzle PSI Rating & Suggested Torque (lubricated).

| Diameter | PSI Rating | Suggested Torque |
|----------|------------|------------------|
| 16" | 50 | 275 ft. lbs. |
| 18" | 50 | 390 ft. lbs. |
| 20" | 50 | 390 ft. lbs. |
| 24" | 50 | 550 ft. lbs. |

Torque tolerance is ± 5 for sizes 12" and smaller and ± 10 for sizes greater than 12".



OPERATION & MAINTENANCE INSTRUCTIONS

Torque Increments for Legacy Cross-Pattern Tightening

(DO NOT OVER TORQUE THE BOLTS)

- Step 1: Make sure ALL threads are properly lubricated.
- Step 2: Hand tighten all bolts. Check flange gap around circumference for uniformity. If the gap around the circumference is not reasonably uniform, make the appropriate adjustments by selective tightening before proceeding.
- Step 3: Tighten to 20% to 25% of Maximum Torque. Check flange gap around circumference for uniformity. If the gap around the circumference is not reasonably uniform, make the appropriate adjustments by selective tightening before proceeding.
- Step 4: Tighten to 45% to 50% of Maximum Torque. Check flange gap around circumference for uniformity. If the gap around the circumference is not reasonably uniform, make the appropriate adjustments by selective tightening before proceeding.
- Step 5: Tighten to 100% of Maximum Torque. Check flange gap around circumference for uniformity. If the gap around the circumference is not reasonably uniform, make the appropriate adjustments by selective tightening before proceeding.
- Step 6: It is possible that the gasket will relax after seating. Retightening is recommended 24 hours after installation to compensate for the relaxation. **DO NOT** over torque the bolts.



OPERATION & MAINTENANCE INSTRUCTIONS

Flanged Nozzle Allowable Loads

| Size | A | B | C |
|-------|----------|--------------|----------|
| 1 | 100 LBS. | 50 FT./LBS. | 100 LBS. |
| 1-1/2 | 100 LBS. | 100 FT./LBS. | 100 LBS. |
| 2 | 100 LBS. | 100 FT./LBS. | 100 LBS. |
| 3 | 100 LBS. | 100 FT./LBS. | 100 LBS. |
| 4 | 100 LBS. | 100 FT./LBS. | 100 LBS. |
| 6 | 100 LBS. | 100 FT./LBS. | 100 LBS. |
| 8 | 100 LBS. | 100 FT./LBS. | 100 LBS. |
| 10 | 100 LBS. | 100 FT./LBS. | 100 LBS. |
| 12 | 100 LBS. | 100 FT./LBS. | 100 LBS. |

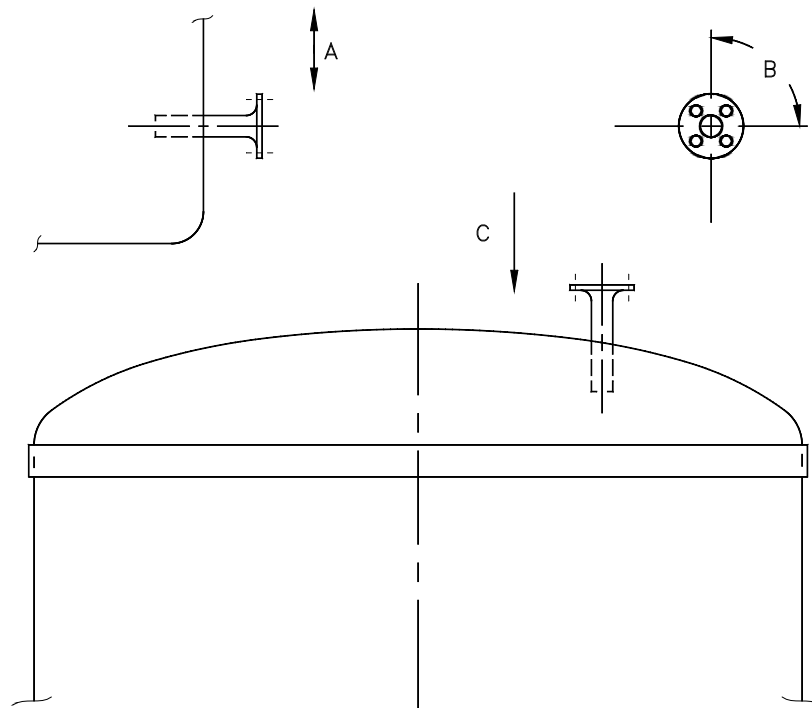



OPERATION & MAINTENANCE INSTRUCTIONS

Brine-Tek™ Design / Operation Criteria

All types of salt can be used in the BTT **Brine-Tek™** Downflow Brinemakers. Pelletized Salt, Rock Salt, Solar and Food Grade Granulated Salt. A graded gravel bed is required when using granulated salt.

Filtration Zone - 36 inches of salt and a graded gravel bed just below the water and covering the brine collection cistern. This separates undissolved crystals and insolubles from the brine. The gravel bed also encourages a uniform cross-sectional draw of brine. Graded gravel consists of 7 inches of 1/4" x 1/2" covered with 5 inches of 1/8" x 1/4" material.

Brine Collector Cistern - Six lateral stringers of 6.625 inch OD, slotted PVC pipe connected to a center plenum. Uniform collection of gravity-fed brine over the cross-sectional area of the brinemaker, discourages channeling of the filtration zone.

Liquid Head - Minimum of 7 feet, fluctuating between 7-8 ft. Brine fluidizes the salt mass to discourage channeling and ensures a consistent gravity feed of brine through the filtration zone into the collecting cistern.

Minimum Salt Level - Minimum undissolved salt level in the brinemaker is 5 ft. from the base to ensure fully saturated brine and to maintain sufficient pressure on the filtration zone to avoid channeling. **(Relative to salt delivery)** Indicator Yo-Yo Systems are recommended to determine when there is adequate space to accept a shipment of salt. Heat may be required in cold climates.

Brine Withdrawal - Preferred method is gravity transfer to a reservoir tank where it can be pumped to use points. If directly pumped from the brinemaker, use a plastic seal less, magnetic drive, centrifugal pump with a maximum internal suction of 75 psi to avoid compaction and clogging of the filtration zone.

Brinemaking Rates - Not to exceed 0.5 gpm per ft² of cross-sectional area to ensure saturation and avoidance of channeling. Maximum brinemaking rate is 15gpm for 7 ft. diameter tanks, 20 gpm for 8 ft. diameter tanks, 25 gpm for 9 ft. diameter tanks, 33 gpm for 10 ft. diameter tanks, 45 gpm for 11.5 ft. diameter tanks, 50 gpm for 12 ft. diameter tanks, and 66 gpm for 14 ft. diameter tanks. **(These rates are for granulated salt systems; rock salt or solar salt brinemaking rates are approximately 60% of the granulated rates)**

Free Board - There should be at least one foot of sidewall freeboard upon salt delivery to ensure proper separation of salt & conveying air & avoid plugging the fill pipe & dust vent orifices.

Pneumatic Fill Pipe - Each brinemaker comes complete with a 4"dia. 304 stainless steel fill pipe with wide angle bends and center fill to distribute salt evenly over the cross-sectional area.

Dust Control - An 8" vent pipe is supplied to neutralize pressure. A water injector opening (3/4" NPT) on the fill pipe at a 45° angle to inject 3-5 gpm of water during filling. Injection reduces particle attrition during fill and dampens dust. A 30 to 70 micron porosity polyester dust bag on the end of the dust vent is also supplied. The dust bag should be cleaned after each salt delivery.

