



Because your life is on the line!

100 North Thirteenth Street • Franklin, PA 16323 • Toll Free: 877.228.9327 • 814.437.1808

fax: 814.437.2544 • fcp@velocity.net • www.frenchcreekproduction.com

Proudly Made in the U.S.A.

User Instructions – Ladder/Rigid Rail Climbing System

This document serves as the Manufacturer's Instructions, and is to be used as part of an employee training program for the system, as required by OSHA.

ATTENTION: This product serves as part of a fall protection system. All users must read, understand, and follow the manufacturer's instructions for each and every component of the system. All instructions must be followed for proper application, installation, use, and maintenance of this product. Changing the product, misuse of the product, or failure to follow instructions may result in serious injury or death.

Record the system data on the Inspection and Maintenance Log.

If you have any questions concerning the application, installation, use, or maintenance of this product, please contact FrenchCreek Production.

ATTENTION: Improper use of this system or failure to follow instructions and markings may result in serious injury or death.

1.0 APPLICATION

1.1 PURPOSE:

FCP's Vertical Rail Systems are designed to be incorporated into a fall arrest or travel restraint system where worker mobility and fall protection is required. When installed on a ladder and used in conjunction with an FCP rail trolley, and harness, the system allows users to move freely along a rail without the need to push, pull or hold any part of the system while also providing fall protection if a slip or fall occurs, where the trolley will lock onto the rail immediately to arrest the fall.

1.2 LIMITATIONS:

The following limitations apply to the installation and use of FrenchCreek Production's Vertical Rail System. Other limitations may also apply.

- a. CONNECTION LENGTH:** The connection between the carrier or rail and the point of attachment to the body harness may not exceed 9 inches. Using FrenchCreek Production supplied carabiner, the linkage length is 7 inches.
- b. ANCHORAGES:** When mounting rail to a ladder, intermediate mounting clamps must be placed with no more than 6' of spacing in between. The top and bottom clamp must be within 12" of the top and bottom of the rail, respectively.
- c. SYSTEM CAPACITY:** The maximum capacity for the FCP Vertical Rail Trolley is 310 lbs. Multiple users may not be attached to a single trolley. Two users are permitted to use the rail with individual trolleys when used for rescue.

d. FALL CLEARANCE: Proper clearance must be present below the worker to arrest a fall and avoid striking a lower level, obstruction, or the ground. It is important to maintain an unobstructed climbing path or envelope for the climber and the system.

e. BODY SUPPORT: Proper body support is essential. A FrenchCreek full body harness must be used when connecting to the FCP Vertical Rail System.

f. PHYSICAL / ENVIRONMENTAL HAZARDS: Additional precautions may be necessary to reduce injury to the user or damage to the system, in locations that present physical or environmental hazards. Hazards may include, but are not limited to: heat, chemicals, corrosive environments, high voltage power lines, gases, machinery, and sharp edges. Please contact FrenchCreek Production if you have questions about using this product where hazards may exist.

1.3 APPLICABLE STANDARDS: Refer to the national standards including ANSI Z359.0, 1, 2 and 16, local, state, and federal including OSHA 1910.29(i) requirements for more information on personal fall arrest systems.

2.0 SYSTEM REQUIREMENTS

2.1 PERSONAL FALL ARREST SYSTEM COMPONENTS: FCP's Vertical rail System must be used with FrenchCreek approved components and subsystems. Other components may be incompatible, which could directly affect the safety and reliability of the entire system. Personal fall arrest components used with this system must meet all applicable OSHA and ANSI requirements. The connecting subsystem between the harness and rail must limit fall arrest forces to 1,800 lbs. or less with an average force less than 1,350 lbs. or less. A FrenchCreek full body harness must be used with this system.

2.2 PERSONAL FALL ARREST SYSTEM CONNECTORS: Connectors used in attaching to the vertical rail system (hooks, carabiners, etc...) must support at least 5,000 lbs. Connectors and attachments must be compatible in size, shape, and strength. Non-compatible connectors may disengage. Only use locking connectors with this system.

2.3 ANCHORAGE CONNECTORS: All connectors used in attaching the rail to the ladder must be compatible with the connection point on the system. The connection must be positive and capable of sustaining a 3,600 lb. load without failure.

2.4 CONNECTING SUBSYSTEM: The connecting subsystem is the portion of the personal fall arrest system that is used to connect between the vertical rail subsystem and harness fall arrest attachment element.

3.0 OPERATION AND USE

ATTENTION: Do not alter the components, intentions, or use of this system. Use caution when using this system around hazards that include, but are not limited to: heat, chemicals, corrosive environments, high voltage power lines, gases, machinery, and sharp edges. Use caution when using the system around moving machinery and electrical hazards. Additionally, caution should be used when connecting subsystems and personal fall arrest systems may be exposed to sharp edges or abrasive surfaces.

ATTENTION: Age and fitness level can affect your ability to withstand fall arrest forces. If for any reason, you doubt your body's ability to withstand fall forces, please consult a doctor before using this system. Pregnant women and minors are not approved to use this system.

ATTENTION: Do not shorten, extend or modify the connection linkage length. Do not use combinations of components or subsystems which may interfere with the safe function of each other.

3.1 BEFORE EACH USE: Before each use, inspect this product according to the steps listed in section 5.3. Do not use this product if inspection reveals an unsafe or defective condition. Examine, analyze, consider, and plan all factors that may affect the safety of the workers, while using the FCP Vertical Rail System.

- a. Read and understand all of the manufacturer's instructions for each component of the FCP Vertical Rail System. All FCP harnesses and connecting systems are supplied with separate user instructions. Keep all instructions for future reference.
- b. Test the system to ensure that the trolley is locking as intended

3.2 INSTALLATION – ALUMINUM RAIL:

General Installation

The Safety rail consists of a bottom rail, one or more intermediate rails and a top rail. Start the bottom rail approximately 3' from the bottom of ladder, ground or platform. Locate rail midway on ladder or climbway to give ample foot room on steps. The first clamp should be located within 1' of lower end of bottom rail. Throughout the remaining height of ladder or tower, attach clamps at 4' to 6' intervals. Clamps are attached to the T-slot of the rail with 3/8" bolts. After the bottom rail is secured, the regular section in turn can be raised and similarly secured. The top rail can be installed with stop-bolt at top.

Note: On steel ladders or towers, leave approximately 1/16" expansion gap between rail sections.

Maintain straightness and joint evenness. Keep rail free of burrs. Do not Paint.

Center Mounted

1. Lay out all rail sections on ground.
2. Place mounting bolts in the T-slot located on the back of rail section. Predetermine clamp locations based on standard 4' to 6' spacing. Clamp location for the first or lower rail section should be within 6" to 12" from lower end of rail.
3. To prevent bolts from falling out of position when raising rail to a vertical position, place a piece of masking tape below each bolt at the predetermined locations. The two bolts used for each clamp location would be spaced accordingly to coincide with the clamp hole spacing and to ensure that the ladder rungs fit between the mounting bolts when safety rail section is placed against the ladder. Following this procedure will allow the installer to easily place the attachment clamps over the ladder rungs and tighten with lock washers and nuts.
4. When more than one rail section is being installed, attach a splice channel to the top end of the lower rail section before attaching to ladder. Intermediate and top sections can now be

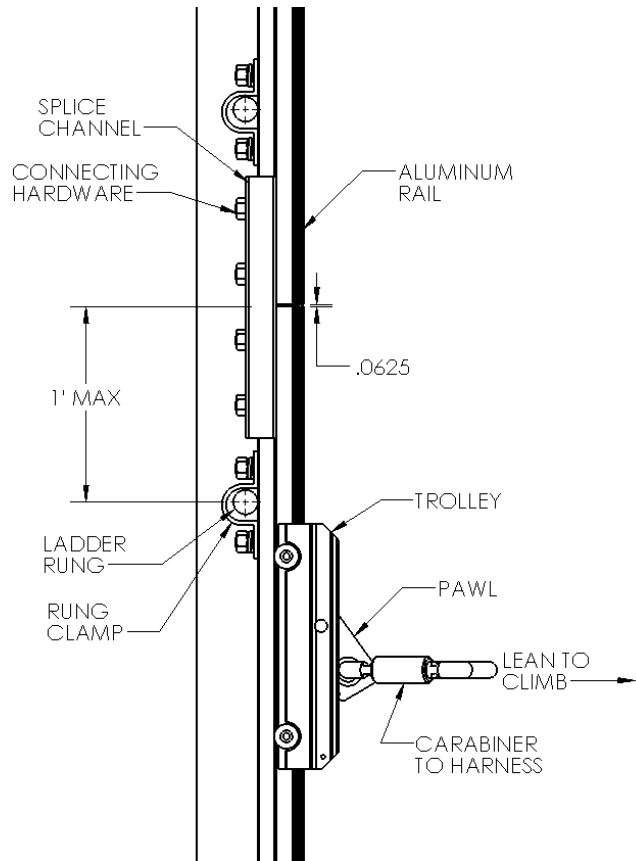

added. Follow previous instructions with regard to bolts and attachment clamps.

Note: A mounting clamp should be located directly below the splice channel (closest rung). It is important that a 1/16" expansion gap be maintained between rail sections.

5. A stop bolt can be used whenever the top rail section terminates at the top of a ladder. A stop bolt is supplied when this is requested. The stop bolt is used to restrict the safety trolley from being removed accidentally from the safety rail. If the trolley were to be removed and dropped to ground level, it could present a safety hazard to the climber as they would no longer be able to attach themselves to the rail system while still on the ladder.

6. A removable extension may be used to access a permanent rail system/ladder from the top when a permanent extension is not possible or desirable. The extension is positioned into the existing permanent rail with a machined high-strength alignment bar and support channel.

Note: When safety rail is installed on a ladder that accesses a landing or platform, the safety rail should be extended a minimum of 3.5' to a maximum of 4.5' above the platform floor. This allows the climber to step onto the platform while still attached to the safety rail. This applies to both center and side mounted rail systems.

7. It is normally recommended that one rail section be raised/ installed at a time. However, it is possible to raise up two 20' rail sections. The splice channel joining the two sections must be properly tightened before raising.

8. Safety harness is supplied with center waist D-rings and side waist D-rings for attaching to carabiner of safety trolley

Note: Raising/installing more than one section at a time can only be done if proper equipment is available to lift section and when rail is being installed on an exterior non-enclosed ladder only. This would not apply to interior ladders

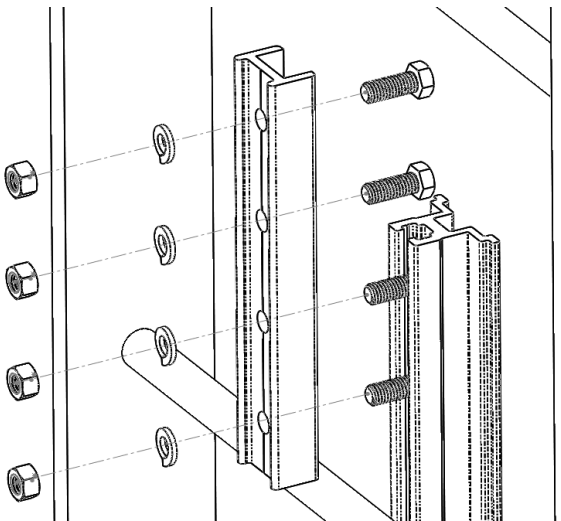

Side Mounted

1. Attach angle brackets to safety rail before final attachment to ladder riser (stringer). After positioning brackets at recommended spacing, it is suggested that mounting bolts and nut/lock washer assemblies be finger tight only to allow for final adjustment if required. When safety rail section is positioned against ladder riser, attach U-bolts and companion brackets.

Note: It is suggested that safety rail be installed on right hand ladder riser (stringer)

2. Safety harness is supplied with center waist D-rings and side waist D-rings for attaching to carabiner of safety trolley.

3.3 INSTALLATION – STAINLESS RAIL

The stainless safety rail consists of a bottom rail, one or more intermediate rails, and a top rail. The design of the rail is specific to your system and the holes have already been punched for the necessary rung clamp attachment. The rail is installed using 5/16 x 1-1/4” carriage bolts. The heads have been ground to allow for proper trolley clearance.

1. Install bottom section (shortest section of rail) by placing rail in center of ladder to give ample foot room on rungs on either side of the rail. Rail will start approximately 3’ up from the ground or on 3rd rung. There will be six (6) inches of rail below this rung. Rail is oriented to the user with the center of the rail mating with the rungs or steps. The wings of the rail should not contact the rungs or steps.
2. The end holes on the rail are spaced 1-1/8” apart on center and are for connecting the other sections of rail. Holes that are spaced 2-3/4” apart are for the clamps.
3. Install carriage bolts into the square holes provided for the rung clamps. Place the two (2) hole spacer bar onto the two bolts and against the back side of the rail. Place Rail against ladder so that one of the bolts is above and one is below the rung to be clamped to. Place clamp onto bolts so the rung is encapsulated. Use a lock washer and nut on each bolt. Tighten bolts to a snug fit. Some adjustment may be required when installing several sections of rail together.
4. Secure next section of rail in place by using the four (4) hole splice bar. The two square holes on the end of the rail just installed will be attached to the first two holes on the splice bar. Use carriage bolts provided. The splice bar will have two more holes for connection to the next piece of rail. Clamp next section of rail into place using step #3.
5. Install next section of rail using the steps 3 and 4.
6. If a removable extension is to be used with the system, the top section of rail must have the mating channel located at the top of the system. The top section will have a channel welded onto the back side of the rail to accept the removable extension. Mount this section of rail in the same manner as above. There should be sufficient clearance between the top section of rail and any hatch cover or lid.
7. After all sections are installed and alignment is correct, all bolt assemblies must be tightened.
8. The trolley is installed with the arrows pointing up and will freely travel up the rail. The trolley will lock onto the rail when pulled downward.

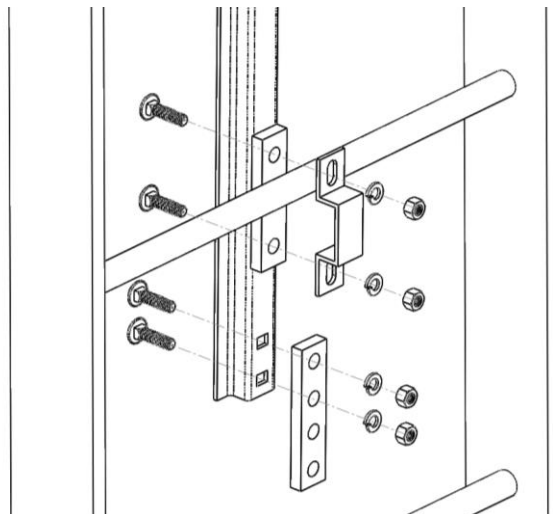

3.4 COMPATIBILITY

Rail	Trolley	Removable Extension	Hardware Material
1-1100-AR (Aluminum)	2-1200A-AT 2-1221A-AT 2-1224A-AT	5-1501	Stainless Steel Galvanized Steel
1-1105-SS (Stainless Steel)	2-1224A-AT	5-1502B	Stainless Steel
1-1100-CR (Curved)	2-1221A-AT 2-1200A-AT		Stainless Steel Galvanized Steel

3.5 OPERATION:

1. Ensuring that the trolley is positioned in the correct orientation with indicator arrows pointing upward, pull back on the trolley pawl and slide onto rail. The pawl mechanism should engage the center of the rail and stay locked in place.
2. Attach harness snugly around waist (Refer to separate instructions for donning body harness). Put excess strap through loop. With d-ring at front, attach to carabiner.
3. Lean slightly away from rail to disengage pawl. Then, begin to climb, keeping tension on the harness/trolley while climbing or descending. **Safety trolley should be level with climber's waist when climbing or descending**
4. Trolley engages rail and locks when outward tension ceases.

ATTENTION: Do not use this system for work positioning. A separate work positioning system must be utilized

ATTENTION: Holding the sleeve during ascent or decent could hinder the safe operation of the braking mechanism and should be done only from a safe position where there is no risk of a fall.

ATTENTION: The user must establish a rescue plan and the means at hand to implement that plan whenever the system is in use.

4.0 TRAINING

4.1 It is the responsibility of all users of this equipment to fully understand these instructions, to become trained in the proper methods concerning the application, installation, use, maintenance, and removal of this product, and to be aware of the consequences of improper methods concerning the application, installation, use, maintenance, and removal of this product.

This document is not a substitute for a comprehensive training program. Training should be provided on an ongoing basis to ensure user proficiency.

5.0 INSPECTION

5.1 PRIOR TO INSTALLATION: All system components must be inspected by a qualified person, in accordance to the manufacturer's guidelines. A formal inspection by a qualified person (other than the user) must be performed, at minimum, on an annual basis. Items found to be defective must be removed from the workplace immediately, and replaced. Record the results of each inspection in an inspection

and maintenance log.

5.2 INSTALLED SYSTEMS: An inspection by a qualified person must be completed after the vertical rail system is installed. The system must be inspected prior to each days use. Periodic inspections should be performed at least monthly, or more frequently as site conditions change or require. Inspections of installed systems should include the inspection steps listed in section 5.3.

5.3 PRIOR TO SYSTEM USE:

Please follow the following steps:

1. Inspect all metal parts for damage (rust, corrosion, cracks, deformities, etc...).
2. Inspect the Trolley

5.4 If this equipment is ever subjected to the forces of a fall or if it fails to pass inspection, it must be immediately removed from service and destroyed, or returned to FrenchCreek Production for inspection and/or repair.

5.5 USER EQUIPMENT: Inspect, maintain, service, and store all equipment used with this vertical rail system according to the Manufacturer’s instructions.

6.0 MAINTENANCE, SERVICE, STORAGE

FCP’s Vertical Rail components require no scheduled maintenance other than the repair or replacement of items found defective during inspections. See section 5.0. If components become heavily soiled with grease, paint, or other substances, clean with appropriate cleaning solutions. Do not use corrosive chemicals that may damage the system or the system components. Store all components for the system in a clean, dry, cool enclosure.

ATTENTION: Only FrenchCreek Production or entities authorized in writing by FrenchCreek Production may repair vertical rail system and system components.

7.0 SPECIFICATIONS

7.1 MATERIALS:

- | | |
|------------|---|
| 1-1100-AR | 6061-T6Aluminum w/ A22 Anodic Coating
Options of Galvanized and 316 stainless steel mounting hardware |
| 1-1105-SS | 316 Stainless Steel – cold formed from 11 gage
316 Stainless Steel Mounting Hardware |
| 2-1200A-AT | 6061-T6Aluminum w/ A22 Anodic Coating
Stainless Steel Pawl
Stainless Steel Expansion Spring
Alloy Steel Carabiner
Polyoxymethylene Wheels
Various Stainless Steel Pins |

See lanyard and harness instructions for material specifications

7.2 MARKINGS:

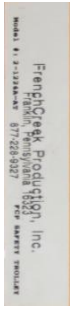

**Identification
Label**



**Orientation
Marking**

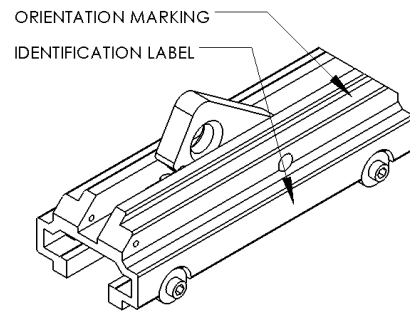

Inspection and Maintenance Log

DATE OF MANUFACTURE: _____

MODEL NUMBER: _____

DATE PURCHASED: _____

Inspection Date	Inspection Items Noted	Corrective Action Taken	Maintenance Performed
Approved By:			
Approved By:			
Approved By:			
Approved By:			
Approved By:			
Approved By:			
Approved By:			

LADDER ANCHOR EXTENSION

Aluminum Rail System

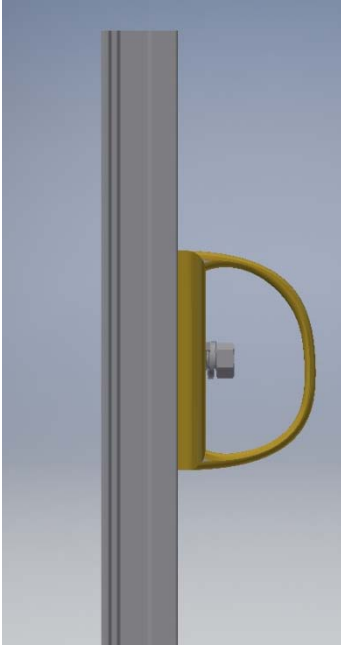
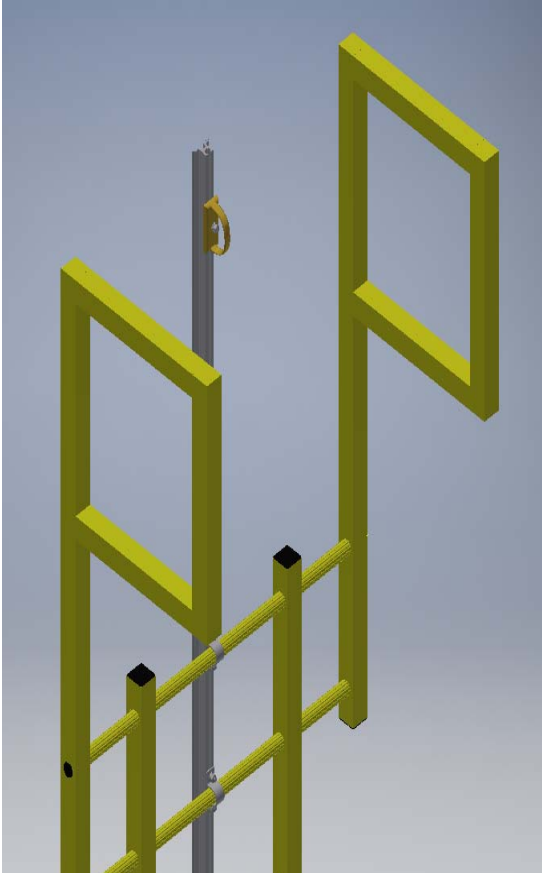

LADDER ANCHOR EXTENSION

Stainless Steel Rail System

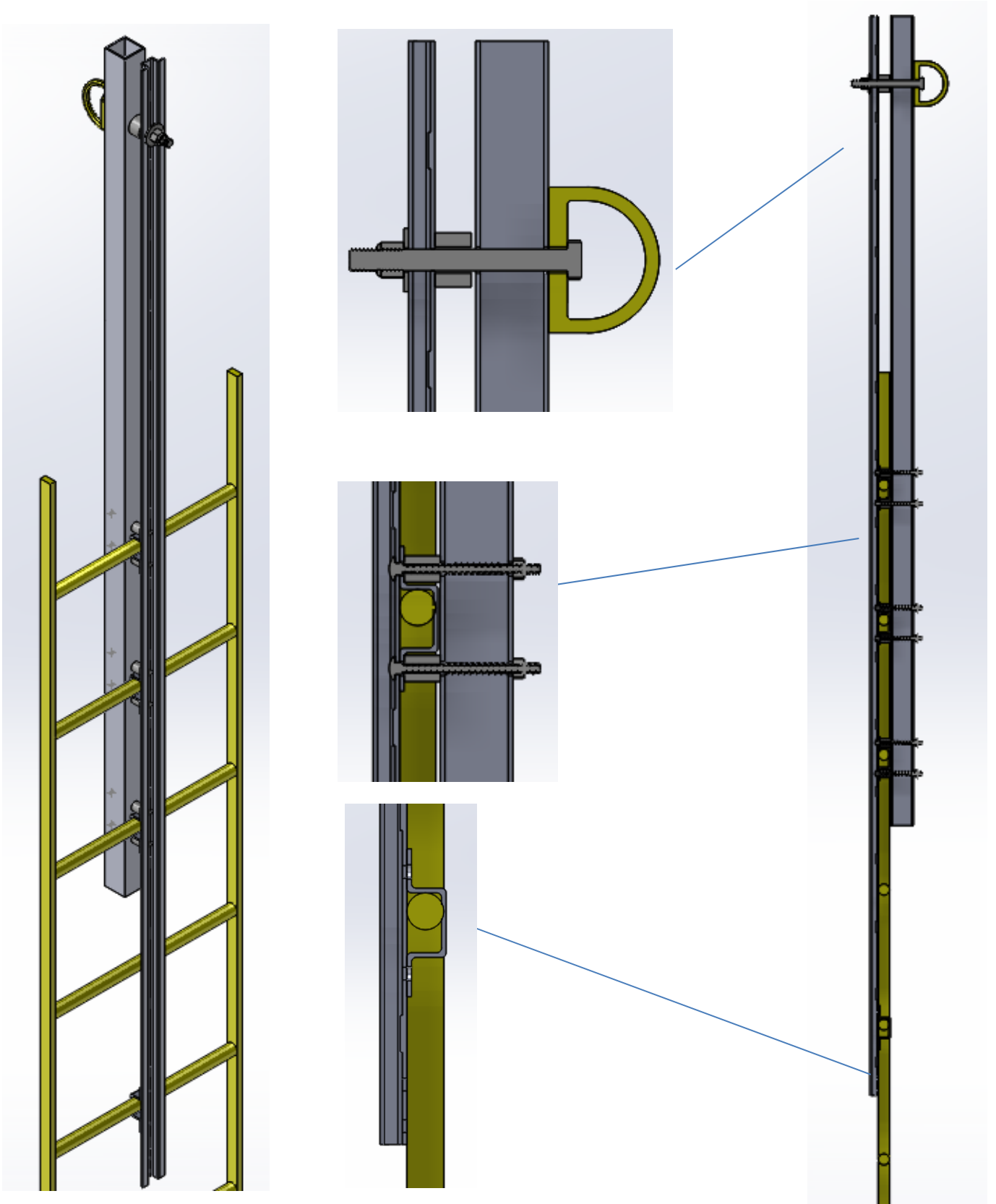



200 N. Gooding Street – P.O. Box 160 – Belding, MI 48809-0160
Phone: (616) 794-1130 Toll Free: (800) 253-4252 Fax: (616) 794-3666
E-Mail: sales@beldingtank.com Website: www.beldingtank.com

“Quality Is Our Standard...Customer Service Is Our Specialty”

June 14, 2018

Subject: French Creek Production Ladder/Rigid Rail Climbing System
Additional Instructions for Top Rail D-Ring Mounting & Dismounting

Your Rail Climbing System comes complete with a full body harness which includes a front center d-ring for climbing ladders. This d-ring is to connect to the trolley to move along the rail. It also comes complete with a safety lanyard. For ease of use, one end of the lanyard is to be connected to the back d-ring of the harness and one to the side d-ring. A top mounted d-ring has been provided at the top of the rail for use when exiting the ladder to the tank top handrail assembly and vice versa.

Climbing Procedures:

1. Connect safety lanyard to harness back d-ring and side d-ring.
2. Mount trolley on climbing rail.
3. Connect harness front-center d-ring to the trolley.

Climb Completed at the Top Rung of Ladder:

1. Connect safety lanyard from side d-ring to Rail D-Ring.
2. Disconnect front harness d-ring from trolley.
3. Exit ladder through handrail safety gate.

Inside Handrail Assembly on Tank Top Head:

1. Reach over handrail safety gate and disconnect safety lanyard from rail d-ring and re-attach to harness side d-ring.
2. Conduct your business.

Top Head Visit Complete Ready to Descend via Ladder and Rail System:

1. PRIOR to exiting handrail assembly, reach over handrail safety gate and connect safety lanyard from harness side d-ring to Rail D-Ring.
2. Exit handrail through safety gate.
3. Connect harness front-center d-ring to the trolley.
4. Disconnect safety lanyard from Rail D-Ring and connect to harness side d-ring.
5. Have a safe and pleasant ladder descent.

Carefully read the entire User Instructions from French Creek Production.

enter the NEXT LEVEL



High-strength Webbing
Certified, synthetic webbing provides UV and chemical resistance. Custom color options are available.

Integral strato-lite Back/Shoulder Pad & Waist Pad
Flame resistant open cell foam with air-mesh fabric for softness, breathability, and moisture control.

D-ring Options
D-rings are zinc plated and powder coated providing high corrosion resistance. Many options are available.

Label Cover
Heavy-duty, abrasion resistant velcro label cover protects label information.



High-strength Stitching
High-strength, high-contrast stitching for ultra performance and extraordinary visual appeal.

Integral strato-lite Comfort Leg Pads
Flame resistant open cell foam with air-mesh fabric for softness, breathability, and moisture control.

Subpelvic Strap
Additional rear strap provides extra comfort & security.

6 Point Adjustment
Provides perfect fit & comfort.

Buckle Options
Buckles are zinc plated and powder coated black providing extended corrosion resistance. Many buckle options are available. Please see part numbers and descriptions.

Lanyard Retainers & Webbing Keepers
Thermo-formed retainers and keepers on both sides of the chest straps.

D-ring Options
D-rings are zinc plated and powder coated black, providing extended corrosion resistance. Many D-ring options are available. Please see part numbers and descriptions.

Integral strato-lite Comfort Leg Pads
Flame resistant open cell foam with air-mesh fabric for softness, breathability, and moisture control.

OPTIONS for the STRATOS Harness:

- Option B - hip D-rings for positioning
- Option D - shoulder D-rings
- Option 9 - additional back D-ring with extension strap built into harness
- Option H - chest D-ring
- Option ID - TRACKER chip, provides permanent RFID identification
- Option U-STEP - suspension trauma straps

Model Shown: 22870B

All models come standard in Green/Black

in fall protection

The innovative STRATOS Series of full body harnesses exceed expectations at the highest level. Designed with safety, durability, and maximum comfort as the finished product, the FrenchCreek STRATOS Series hit the mark. All STRATOS Series harnesses come complete with strato-lite comfort shoulder/back pad and leg pads permanently affixed to keep them in the ideal position. Strato-lite padding is specifically designed with open-celled air-mesh for breathability and moisture control for maximum comfort. Meeting and exceeding OSHA and ANSI standards, this American Made STRATOS Series of harnesses can truly be considered the Professional's Choice.



22650 - 5 point adjustment with grommet/tongue buckle leg straps, as shown

22850B - 6 point adjustment with comfort waist pad & removable tool belt, grommet/tongue buckle leg straps, & hip positioning D-rings

Similar Models:

Similar Models:

22650B - 22650 with hip positioning D-rings

22870B - 6 point adjustment with comfort waist pad & removable tool belt, quick-connect bayonet leg straps, & hip positioning D-rings

22670 - 5 point adjustment with quick-connect bayonet leg straps

22670B - 22670 with hip positioning D-rings

*Weights for the 22850 Series start at 4.2 lbs.

*Weights for the 22650 Series start at 2.9 lbs.

♦♦ = Quick Ship Item

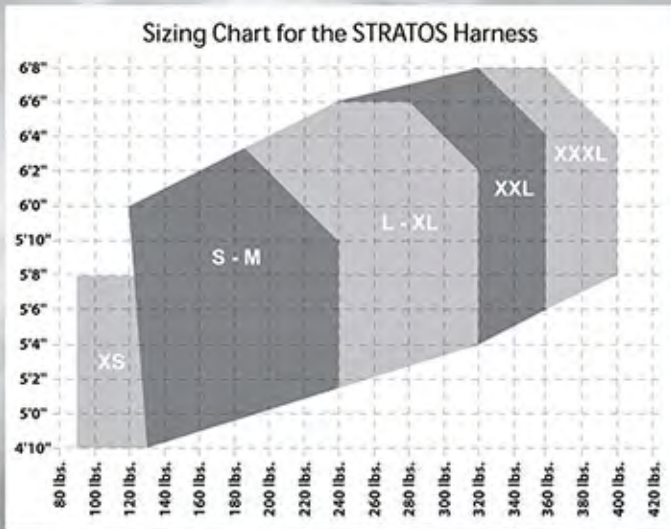

COLOR OPTIONS for the STRATOS Harness:



*All harnesses come standard in GREEN webbing

LEG BUCKLE OPTIONS for the STRATOS Harness:



ROGUE

SELF-RETRACTING LIFELINE

8' sub-compact Self-Retracting Lifeline



self retracting lifelines - ROGUE

ROGUE PART NUMBERS & ORDERING OPTIONS

ROGUE SRL Single-Leg Model Selections			
Single-Leg Model #	Housing/Swivel Connector	Lifeline Connector	Weight (lbs)
MRG3-0Z	#354-4 1" opening, steel carabiner	#Z74 3/4" steel locking snap	3.20
MRG3-0SZ	#354-4 1" opening, steel carabiner	#RL-28 3/4" steel swivel locking snap	3.45
MRG3-4Z	#354-4 1" opening, steel carabiner	#Z136 2 1/2" steel locking rebar snap	4.10
MRG0Z-0Z	#Z74 3/4" steel locking snap	#Z74 3/4" steel locking snap	3.35
MRG0Z-4Z	#Z74 3/4" steel locking snap	#Z136 2 1/2" steel locking rebar snap	4.25
MRG3A-6A	#354-2A 7/8" aluminum carabiner	#63A 3/4" aluminum captive-eye carabiner	2.30
MRG3A-8A	#354-2A 7/8" aluminum carabiner	#62A 2" aluminum locking carabiner	2.80
MRG4Z-0SZ	#Z136 2 1/2" steel locking rebar snap	#RL-28 3/4" steel swivel locking snap	4.50
MRG1-0Z	Swivel Anchor Loop Only	#Z74 3/4" steel locking snap	2.50
MRG1-0SZ	Swivel Anchor Loop Only	#RL-28 3/4" steel swivel locking snap	2.75
MRG1-4Z	Swivel Anchor Loop Only	#Z136 2 1/2" steel locking rebar snap	3.40
MRGCM-0Z	Cab Mount	#Z74 3/4" steel locking snap	3.20
MRGCM-0SZ	Cab Mount	#RL-28 3/4" steel swivel locking snap	3.40

* If you are interested in a snap hook combination not listed, please inquire.

ROGUE SRL Dual-Leg Model Selections			
Dual-Leg Model #	Housing/Swivel Connector	Lifeline Connector	Weight (lbs)
♦♦ M2RG-0Z	#354-6TL 1/2" steel triple-lock carabiner	#Z74 3/4" steel locking snap	5.45
M2RG-0SZ	#354-6TL 1/2" steel triple-lock carabiner	#RL-28 3/4" steel swivel locking snap	5.95
♦♦ M2RG-4Z	#354-6TL 1/2" steel triple-lock carabiner	#Z136 2 1/2" steel locking rebar snap	7.25
M2RG-6A	#354-6TL 1/2" steel triple-lock carabiner	#63A 3/4" aluminum captive-eye carabiner	4.45
M2RG-8A	#354-6TL 1/2" steel triple-lock carabiner	#62A 2" aluminum locking carabiner	5.45

* To order RFID TRACKER capable units, simply add "ID" to the part number.

ROGUE Features

Swivel Anchor Loop limits twisting, Impact Indicator tears away for visual inspection, Short Fall Arrest Activation, Web Shock-pack tear away to reduce fall forces, 400 lb weight capacity, TRACKER capable, numerous options available.

ROGUE Durability

- High-strength, light weight, corrosion resistant housing, including a stainless steel top swivel
- High Strength wear-resistant webbing allows for 8 feet of capacity
- A variety of 5,000 pound connectors available, reducing the cost of ownership and allowing for customization
- Single or Double-leg connection, meets or exceeds OSHA & ANSi industry standards.

ROGUE Safety Performance

- No annual factory recertification required
- Double-inertia, high-strength stainless steel braking system arrests free falls within inches
- Visual impact indicator warns that the unit has experienced fall-arrest forces and must be removed from service
- Compact energy absorber minimizes fall-arrest forces
- Used in commercial & residential construction, manufacturing, refinery maintenance, utilities, and other industries

tower, ladder, rail climbing systems

FrenchCreek's rigid rail climbing systems provide maximum climbing safety for workers in a multitude of applications, such as: towers, antennas, chimneys, stacks, scaffolds, support poles, wind generators, signs, water tanks, dams, silos, shipboard, ladders, and virtually any place that climbing must be done! The rail attaches quickly and easily to any ladder, step iron, or climbing surface. The trolley moves freely along the rail until a slip or fall occurs, when the trolley instantly locks, and the fall is immediately arrested.

♦♦ = Quick Ship Item

Rails:

- 1-1100-AR - Anodized aluminum climbing rail, with all mounting hardware included.
- 1-1105-SS - 316 stainless steel climbing rail with all mounting hardware included.
- 1-1100-CR - Curved anodized aluminum climbing rail, with all mounting hardware included.

Trolleys:

- ♦♦ 2-1200A-AT - Climbing trolley for straight, vertical aluminum rail, as shown.
- 2-1221A-AT - Aluminum climbing trolley for curved/straight climbing rail.
- 2-1223-AT - Aluminum trolley for horizontal rails, as shown.
- ♦♦ 2-1224A-AT - Climbing trolley for stainless steel & aluminum climbing rails.



2-1200A-AT



Ladder / Rigid Rail Climbing System in use



Horizontal Trolley and Rail System

2-1223-AT

tower, ladder, rail climbing systems optional equipment

♦♦ = Quick Ship Item

Removable Extension - The removable extension is used to access a permanent rail system/ladder from the top, when a permanent extension is not possible or desirable. The extension is positioned into the existing permanent rail with a machined high-strength alignment bar and support channel, as shown.

- ♦♦ 5-1501 - 54" removable aluminum extension rail, as shown.
- ♦♦ 5-1502B - 42" removable stainless steel extension rail.

Ladder Rung Clamps - Ladder rung clamps are included with the FCP Rigid Rail Climbing System, however, you have the option to choose the style of ladder rung clamps that will best fit your installation site. Choose from a variety of shapes and sizes, as shown. Hardware to mount to side riser of ladder is also available. Please inquire at time of ordering.



Ladder Rung Clamps



Removable Extension
5-1501



TOWER SAFETY SYSTEMS

HOW TO USE TS SAFETY RAIL SYSTEM

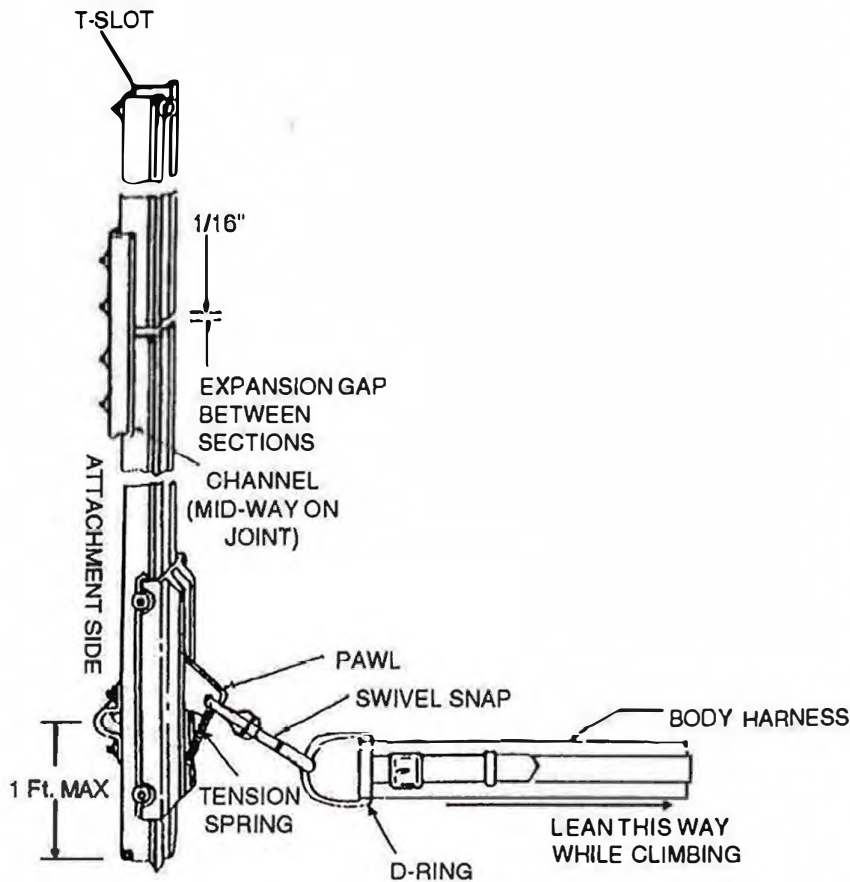

1. Attach harness belt snugly around waist. Put excess strap through loop. With D-ring at front, attach to trolley snap. (Refer to separate instructions for donning body harness.)

2. Lean slightly away from rail to disengage pawl. Then, begin to climb, keeping tension on harness while climbing or descending. **Safety trolley should be level with climber's waist when climbing or descending.**

3. Trolley engages rail and locks when outward tension ceases.

4. *Do not leave trolley and safety harness on TS rail when not in use.*



FCP
FrenchCreek
Production

FrenchCreek Production, Inc
626 13th St.
Franklin, PA 16323

Phone: (877) 228-9327 Fax: (814) 437-2544
Website: www.frenchcreekproduction.com

American Owned, American Made